



Jaro Thermal

We keep the world cool™

SPECIFICATION FOR APPROVAL

Customer _____

Description D C F A N

Jabil Part No. _____

Jaro Model No. JVD0300703HA1A01 REV. 0

Sample Issue No. _____

Sample Issue Date _____

PLEASE SEND ONE COPY OF THIS SPECIFICATION
BACK AFTER YOU SIGNED APPROVAL FOR
PRODUCTION PRE-ARRANGMENT.

PREPARED BY : Adam.Hung DATE : 05/23/2011

CHECKED BY : Jay.Su DATE : 05/23/2011

APPROVED BY : Claire.Wang DATE : 05/23/2011

Jaro Thermal USA offices
6600 Park of Commerce Blvd.
Boca Raton, Florida 33487
www.jarothermal.com
Ph: 561-241-6700
Fx: 561-241-3328

Jaro Thermal Taiwan offices
No. 22, De Min Rd., Nanzi
District, Kaohsiung 81157
www.jarothermal.com
Ph: +886-7366-1120
Fx: +886-7364-4000



SPECIFICATION



Customer	:		Ref: (RoHS)
Jaro Model	:	JVD0300703HA1A01	
Samples attached	:	pcs	
Safety Approval	:	CE	

Description

DIMENSIONS	:	30x30x07	mm
BEARING TYPE	:	Aerospace Fluid Bearing	
RATED VOLTAGE	:	3.3	VDC
OPERATING VOLTAGE	:	2.5	VDC – 6.0 VDC
START-UP VOLTAGE	:	2.5	VDC , NORMAL
REAL CURRENT	:	0.05	Amp
RATED CURRENT	:	0.13	Amp
RATED POWER	:	0.165	Watt
RATED SPEED	:	4200RPM	± 15%
			(IN FREE AIR AT RATED VOLTAGE)
AIR FLOW	:	1.850	CFM (min.: 1.573 CFM)
AIR FLOW	:	0.052	M ³ /MIN (min.: 0.044 M ³ /MIN)
			(IN FREE AIR AT RATED VOLTAGE)
STATIC AIR PRESSURE	:	0.034	Inch H ₂ O (min.: 0.025 Inch H ₂ O)
STATIC AIR PRESSURE	:	0.870	mm H ₂ O (min.: 0.629 mm H ₂ O)
			(IN FREE AIR AT RATED VOLTAGE)
NOISE LEVEL	:	18.6	dB (A) (max.: 20.6 dB(A)) (0.45M)
MOTOR PROTECTION	:	BY	IC
CONNECTION LEAD TYPE	:	WIRE, AWG#	28
LIFE EXPECTANCY	:	70000	Hours at 40°C / 65%
NET WEIGHT	:	3.5	Gram.

Unless otherwise stated, the relative humidity is 65%, and the temperature is 25°C for the standard testing.

Should you have any doubt, please refer to the environmental conditions specified in the acknowledgement document.





SPECIFICATION

JARO MODEL: JVD0300703HA1A01

1 · 0 SCOPE

- 1.1 If the information or other related document is inconsistent with this acknowledgement document, please refer to the acknowledge document.
- 1.2 This documentation defines the mechanical & electrical characteristics of DC brushless fans.
- 1.3 The specification of this product is described in details in the acknowledgement document. No guarantee is given to our product under the use of over specifications.
- 1.4 For any change or amendment to the specifications, such change will be noticed in writing beforehand.
- 1.5 If the product is used on the MIS system, please specify the specification in the purchase order.

2 · 0 MATERIAL

- 2.1 Frame : UL94V-0 Glass Filled polyester (P.B.T)
- 2.2 Fan Blade : UL94V-0 Glass Filled polyester (P.B.T)
- 2.3 Bearing Sys. : Sleeve, oil impregnated.
 Two Ball Bearing
 One Ball one Sleeve
 AEROSPACE FLUID BEARING
 FDB Bearing
- 2.4 RoHS : YES
HF : YES

3 · 0 DIMENSIONS & CONSTRUCTION

All dimensions, Direction of rotation and air flow were specified as per drawing attached.

4 · 0 CHARACTERISTICS & DEFINITION

- 4.1 All rated characteristics were specified as per data sheet enclosed.
- 4.2 Rated Current : Rated Current shall be measured after 3 minutes of continuous rotation at rated voltage.
- 4.3 Rated Speed : Rated Speed shall be measured after 3 minutes of continuous rotation at rated voltage.
- 4.4 Start Voltage : The voltage which is able to start the fan to operate by suddenly switching 'ON'.
- 4.5 Input Power : Input Power shall be measured after 3 minutes of continuous rotation at rated voltage.
- 4.6 Locked Rotor Current : Locked current shall be measured within one minute of rotor locked, after 3 minutes of continuous rotation at rated voltage in clean air.
- 4.7 Air Flow & Static Pressure : The air flow data and static pressures should be determined in accordance with AMCA-210 standard or DIN24163 specification in a double chamber testing with intake – side measurement.
- 4.8 Noise Level : The measurement of noise level is carried out with reference to CNS8753 in an anechoic chamber with the microphone positioned 1 meter from the air intake. Testing fan shall be hung in clean air .

Noise Level Measure

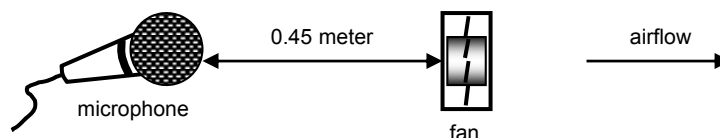



SPECIFICATION

JARO MODEL: JVD0300703HA1A01

5 · 0 MECHANICAL INSPECTION

5.1 Rotation Direction

Counterclockwise when look into impeller side.

5.2 Protection

All fans have integrated protection against locked rotor condition so that there will be no damage to winding or any electronic component.

Restarting is automatic as soon as any constraint to rotation has been released.

As fan placed at dead angle position, and the switch was changed from off to on. Restarting was automatic normal as soon as and proved that this fan is good fan.

5.3 Locked Rotor Protection

No damage shall be found after 72 hours continuously at condition of rotation locked.

Restarting is automatic as soon as constraint to running has been released.

5.4 Avoid the damage, check the correct voltage and proper polarity before connecting with power.

5.5 Free Drop Shock

In minimum package condition, the fan should withstand drops on any three faces from a height of 30cm onto a wood board of 10mm thick.

5.6 Please do not stick a grease and/or an oil to the fan housing or blade which may have a harmful influence by a chemical reaction at high humidity.

5.7 If the fan is reinstalled, please pay special attention to the noise due to the vibration (or resonance).

5.8 During the testing of the fan, please make sure the finger guard is used for safety.

6 · 0 ELECTRICAL INSPECTION

6.1 Insulation Resistance

Not less than 10M ohm between housing and positive end of lead wire (red) at 500V DC.

6.2 Dielectric Strength

No damage should be found at 500 VAC for 60 seconds, measured with 1mA trip current between housing and positive end of lead wire.

6.3 Life Expectancy

The continuous duty life at given temperature after which, 90% of testing units shall still be running.

6.4 While the fan is running, do not intentionally lock the fan for a long time since the overheating of the motor produced by the long-time locking will damage the fan.

7 · 0 ENVIRONMENTAL

7.1 Improper use such as disassembling the fan, being covered with dust, or dipping the fan in water that results in defects is not covered in the warranty. Do not use the fan in the environment with corrosive air or liquid.

7.2 Operating Temperature / Humidity

-20°C to +90°C at humidity 65%+/-20% RH.

7.3 Storage Temperature

All function shall be normal after 500 hours storage at -40°C to +75 °C with a 24 hour recovery period at room temperature.

7.4 Humidity

After 96 hours, 95% RH, 40+/-2°C per MIL-STD-202F, method 103B humidity test, the measured data on insulation resistance and dielectric strength shall meet the specification.

7.5 Do not place or store the fan in the environment with high/low temperature/humidity. Do not store the fan for over 6 months; even if the fan is stored in room temperature for over 6 months, the fan may have the electric current leakage.



SPECIFICATION

JARO MODEL: JVD0300703HA1A01

8 · 0 REMARKS

8.1 Material and construction are subject to change without advance notice. The changes should be within specification.

8.2 All fans shall meet the quality inspection under sampling plan MIL-STD-105E as follow:

Critical 0.25%

Major 1.00%

Minor 2.50%

9 · 0 Notes:

- 9.1 Please do not touch or push the fan blades with fingers or any other object as both the fan blade and ball bearings can be damaged and result in a noise defect..
- 9.2 Do not carry the fan by its lead wires.
- 9.3 If the fan does not have the polarity protection function, the connection of the colored wires should be red + red, and black + black, or else the fan will be damaged in no time.
- 9.4 For the models without reverse connection of polarity protection, please do not connect the lead wire in reverse
- 9.5 Please don't install this fan in series with 2x voltage inputs. For example, if a single fan rated at 12V, then don't install two of them in series with 24V input.
- 9.6. Every specific fan is designed for its certain application (project). Therefore, if you want to use this fan in other application (project), please inform JARO first so that we can confirm whether there is any issue which might be incurred from the reason of this different application (project) or not.



DIMENSION DRAWING



JARO MODEL: JVD0300703HA1A01

10.0 Dimension

DIAGRAM OF DIMENSIONS: Dimensions in millimeters

NOT TO SCALE. ALL COMPONENTS MUST BE ROHS COMPLIANT.

Description: DC Fan with:

UL3265 AWG28

Pin 1 : Red Wire

Pin 2 : Black Wire (-)

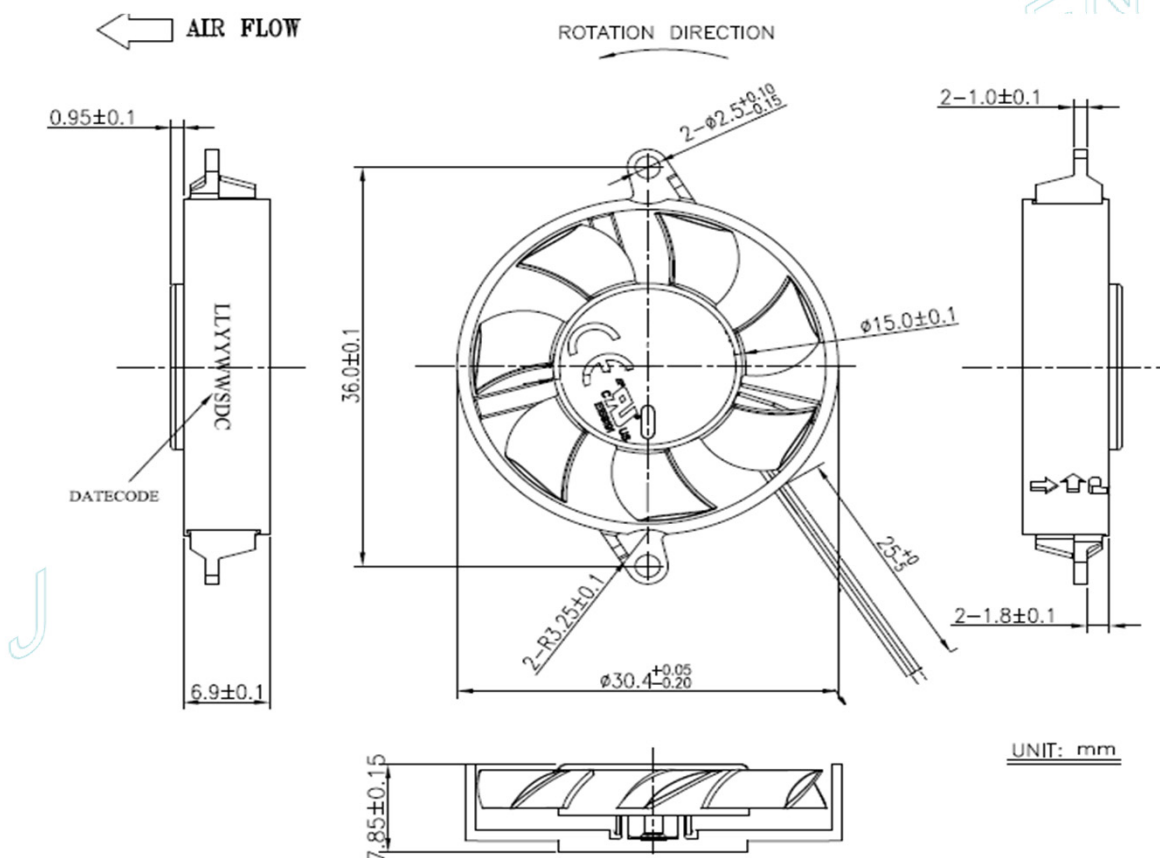

Drawing Note: N/A

Revision	CHANGES	DATE	BY
Original Issue		05/24/2011	Adam Hung
Revision A			
Revision B			



PERFORMANCE CURVE

JARO MODEL: JVD0300703HA1A01

11.0 Performance Curve

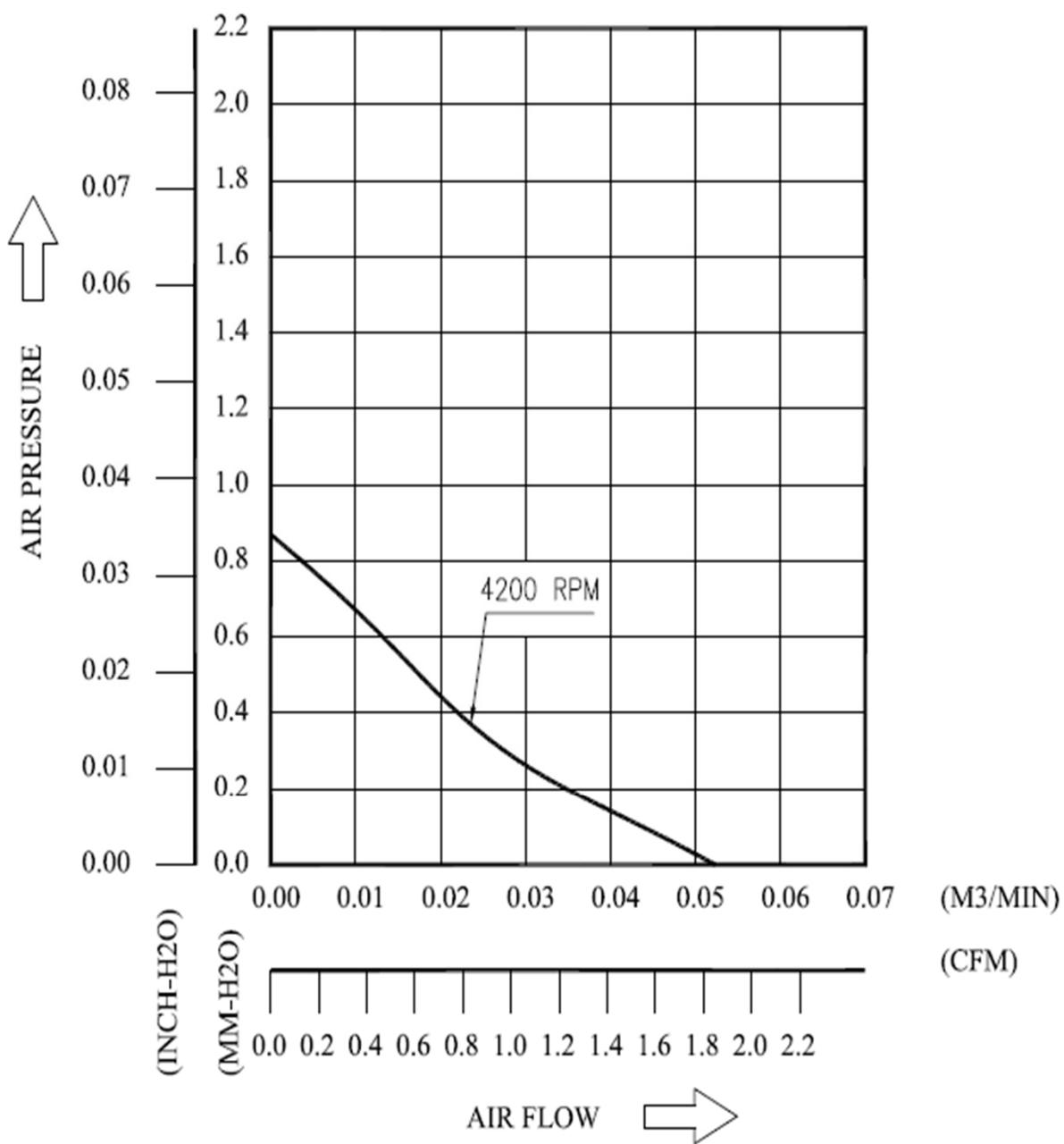



LIFE DATA

JARO MODEL: JVD0300703HA1A01

故障定義 Product Specification & Faivre Definiton	試驗結果：包含故障時間、數據、統計、...等 Test Result : Including Time Of Failure、Datum、Statistics、... ect.																																														
1.風扇不轉 (Fan Not Work) 2.轉速超出規格30% (Speed Over 30% Origin) 3.電流超出規格30% (Current Over 30% Origin)	• 溫度加速因子 TEMP A.F = $e^{(\Delta H / K) \times (\frac{1}{273+Tl} - \frac{1}{273+Th})}$ • 總試驗時間 Total Test Time = 200000 HRS.																																														
Description : 1.性能測試時點 The Time Of Check Point Start : 0Hr, 500Hrs, 1000Hrs And Finished $70^{\circ}\text{C} \text{ MTTF} = \frac{\text{Total test time (T)}}{\text{Total failure (r)}}$ <p style="text-align: center;">GEM TABLE</p> 2. Generalized Exponential Model (for Time-Terminated Test) <table border="1" style="margin-left: auto; margin-right: auto;"> <tr> <td>r</td> <td>0</td> <td>1</td> <td>2</td> <td>3</td> <td>4</td> <td>5</td> </tr> <tr> <td>M</td> <td>2.3026</td> <td>3.8897</td> <td>5.3223</td> <td>6.6808</td> <td>7.99364</td> <td>9.2747</td> </tr> <tr> <td>r</td> <td>6</td> <td>7</td> <td>8</td> <td>9</td> <td>10</td> <td></td> </tr> <tr> <td>M</td> <td>10.5321</td> <td>11.7709</td> <td>12.9947</td> <td>14.2060</td> <td>15.4066</td> <td></td> </tr> </table>	r	0	1	2	3	4	5	M	2.3026	3.8897	5.3223	6.6808	7.99364	9.2747	r	6	7	8	9	10		M	10.5321	11.7709	12.9947	14.2060	15.4066		• 查表得 (MTTF By GEM Table) MTTF = 86858 HRS. • 溫度 / TEMP. / MTTF / L10 <table border="1" style="margin-left: auto; margin-right: auto;"> <thead> <tr> <th>溫度TE MP.</th> <th>信賴水準90% CONFIDENCE LEVEL</th> <th>L10</th> </tr> </thead> <tbody> <tr> <td>30 °C</td> <td>1571333</td> <td>165403</td> </tr> <tr> <td>40 °C</td> <td>710842</td> <td>74826</td> </tr> <tr> <td>50 °C</td> <td>337761</td> <td>35554</td> </tr> <tr> <td>60 °C</td> <td>167824</td> <td>17666</td> </tr> <tr> <td>70 °C</td> <td>86858</td> <td>9143</td> </tr> </tbody> </table>	溫度TE MP.	信賴水準90% CONFIDENCE LEVEL	L10	30 °C	1571333	165403	40 °C	710842	74826	50 °C	337761	35554	60 °C	167824	17666	70 °C	86858	9143
r	0	1	2	3	4	5																																									
M	2.3026	3.8897	5.3223	6.6808	7.99364	9.2747																																									
r	6	7	8	9	10																																										
M	10.5321	11.7709	12.9947	14.2060	15.4066																																										
溫度TE MP.	信賴水準90% CONFIDENCE LEVEL	L10																																													
30 °C	1571333	165403																																													
40 °C	710842	74826																																													
50 °C	337761	35554																																													
60 °C	167824	17666																																													
70 °C	86858	9143																																													
3. Herewith, we could assume as right on the basis of above test result. Besides, if the actual test time exceed the required, it comes out that those fans' L ₁₀ expectancy and MTTF are greater than the warrant. MTTF: Mean Time To Failures. It should be used in a non-repairable system setting. Now we show the MTTF in our life report, that's because we will not repair the failed fans during life experiment. MTBF: Mean Time Between Failures. It should be used in a repairable system setting. Basically, MTBF is equal to MTTF, they use same formula to work out a life data.																																															

