



# JARO THERMAL DATA-SHEET

RoHS  
Compliant

## BRUSHLESS AXIAL COOLING FANS

Customer:		Ref:	
Model Number: AD0412XB-G76(T)-LF			
Samples attached:			
Safety Approval: UL, CUL, TUV, CE			

<u>ITEM</u>	<u>FAN SPECIFICATION &amp; CONDITION</u>	
DIMENSIONS:	40X40X10	MM.
BEARING TYPE:	BALL	
RATED VOLTAGE:	12	VDC.
OPERATING VOLTAGE:	10.8—13.2	VDC.
START-UP VOLTAGE:	9.0	VDC.
RATED CURRENT:	0.25	AMP + 10%(MAX.).
RATED POWER:	3.00	WATT.
RATED SPEED:	8500	RPM +/-10%.
AIR FLOW:	8.9	CFM +/- 10%.
STATIC AIR PRESSURE:	0.195	INCH WATER.
NOISE LEVEL:	38.0	dB + 10%
MOTOR PROTECTION:		BY IMPEDANCE
CONNECTION LEAD TYPE:	WIRE ,AWG#26	
LIFE EXPECTANCY:	50000	HOURS AT 40 degree Celsius.
NET WEIGHT:	24	GRAM.
PACKING:	700 pcs	PER CARTON.

## **SPECIFICATION**

### **1.0 SCOPE**

**This documentation defines the mechanical & electrical characteristics of DC Brushless Fans.**

### **2.0 MATERIAL**

- 2.1 Housing: UL94V-0 Glass Filled Polyester (P.B.T)**
- 2.2 Fan Blade: UL94V-0 Glass Filled Polyester (P.B.T)**
- 2.3 Bearing Type: 2 Ball Bearing**

### **3.0 DIMENSIONS & CONSTRUCTION**

**All dimensions, direction of rotation and airflow were specified as per drawing attached.**

### **4.0 CHARACTERISTICS & DEFINITION**

- 4.1 All rated characteristics were specified as per data sheet enclosed**
- 4.2 Rated Current: shall be measured after 3 minutes of continuous rotation at rated voltage.**
- 4.3 Rated Speed: shall be measured after 3 minutes of continuous rotation at rated voltage.**
- 4.4 Start Voltage: is able to start the fan to operate by suddenly switching on.**
- 4.5 Input Power: shall be measured after 3 minutes of continuous rotation at rated voltage.**
- 4.6 Locked Rotor Current: shall be measured within one minute of rotor locked, after 3 minutes of continuous rotation at rated voltage in clean air.**
- 4.7 Air Flow & Static pressure: The air flow data and static Pressures should be determined in accordance with AMCA standard or DIN24163 specification in a double-chamber testing with intake-side measurement.**
- 4.8 Noise Level: the measurement of noise level is carried out with reference to CNS8753 in an anechoic chamber with the microphone positioned 1 meter from the air intake. Testing fan shall be hung in clean air.**

### **5.0 MECHANICAL INSPECTION**

#### **5.1 Rotation Direction**

**Clockwise with label side facing up. The same direction also indicated by an arrow mark on one side of the housing.**

**5.2 Protection**

All fans have integrated protection against locked rotor condition so that there will be no damage to winding or any electronic component. Restarting is automatic as soon as any constraint to rotation has been released.

As fan placed at dead angle position, and the switch was changed from off to on. Restarting was automatic normal as soon as and proved that this fan is good fan.

**5.3 Locked Rotor protection**

No damage shall be found after 72 hours continuously at condition of rotation locked. Restarting is automatic as soon as constraint to running has been released.

**5.4 Avoid the damage check the correct voltage and proper polarity before connecting with power.**

**5.5 Free drop shock**

In minimum package condition, the fan should withstand drops on any three faces from a height of 30cm onto a wood board of 10mm in thickness.

**6.0 ELECTRICAL INSPECTION**

**6.1 Insulation resistance**

Not less than 10M Ohm between housing and positive end of lead wire (red) at 500 VDC.

**6.2 Dielectric Strength**

No damage should be found at 500 VAC for 60 second, measured with 1mA trip current between housing and positive end of lead wire.

**6.3 Life Expectancy**

The continuous duty life at given temperature after which, 90% of Testing units shall still be running.

**7.0 ENVIRONMENTAL**

**7.1 Operating Temperature**

-10 to +70 degree Celsius at normal humidity.

**7.2 Storage Temperature**

All function shall be normal after 500 hours storage at -40 to +70 degree Celsius, at normal humidity with a 24 hours recovery period at room temperature.

**7.3 Humidity**

After 96 hours, 95% RH, 40 +/- 2 degree Celsius per MIL-STD-202F, method 103B humidity test, the measured data on insulation resistance and dielectric strength shall meet the specification.

**8.0 REMARKS**

**8.1 Material and construction are subject to change without advance notice. The changes should be within specification.**

**8.2 All fans shall meet the quality inspection under sampling plan MIL-STD-105D as follow:**

<b>Critical</b>	<b>0.25%</b>
<b>Major</b>	<b>1.00%</b>
<b>Minor</b>	<b>2.50%</b>

**9.0 OUTLINE STYLING & DIMENSIONS**

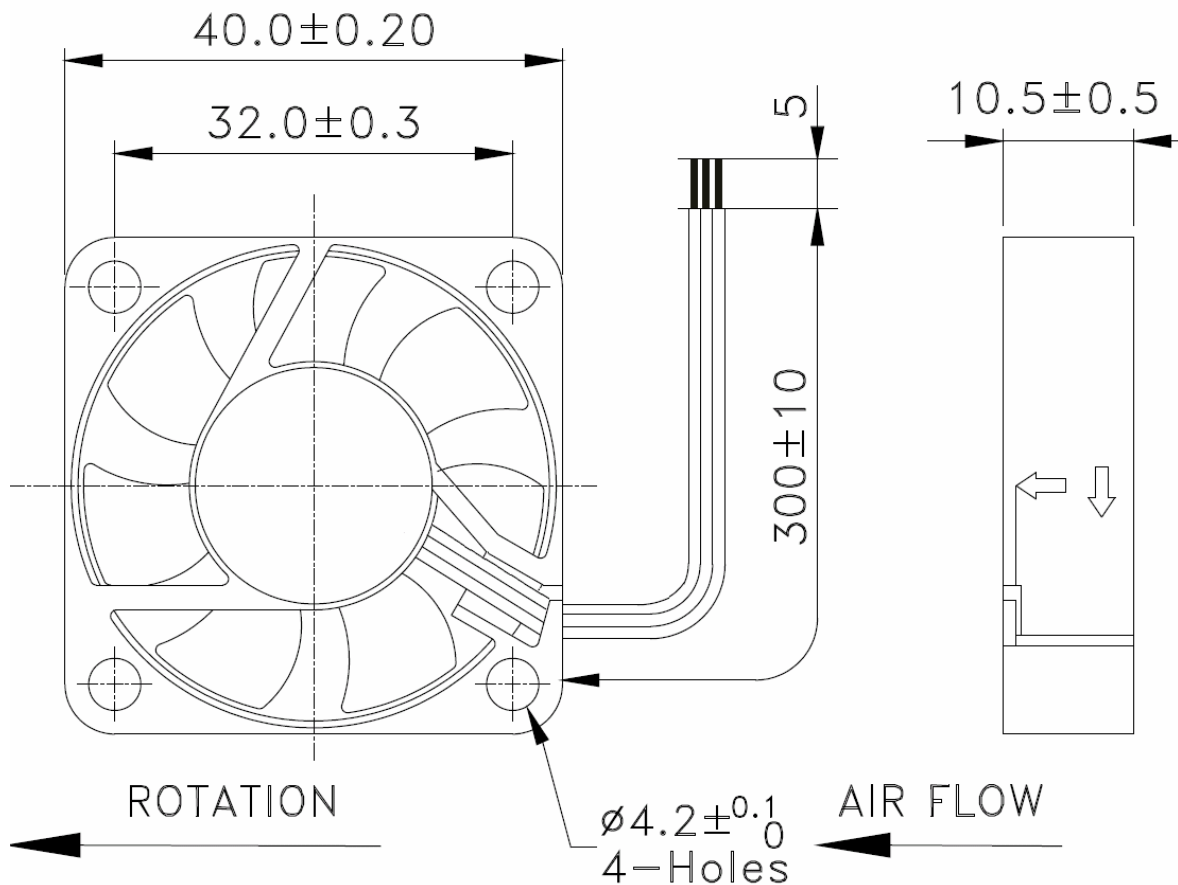

**Please do not touch or push fan blade with fingers or other objects.  
Fan blade or bearings may be damaged and cause a noise defect.**

**LEAD WIRES: UL1007, AWG26, L=300±10mm**

**Red=Positive Black=Negative Blue=FG**