





## SPECIFICATION FOR APPROVAL

## DC Brushless Fan

JARO PART NUMBER: AD1505HX-0R4E-LF	<b>IP-57</b>	
SAFETY APPROVAL: CE		

SPECIFICATIONS	
ITEM	SPECIFICATION / CONDITION
DIMENSIONS	15x15x4mm
BEARING TYPE	Copper Axial Grooved
RATED VOLTAGE	5.0 VDC
OPERATING VOLTAGE RANGE	4.5-5.5 VDC
START-UP VOLTAGE	2.0 VDC
RATED CURRENT	0.035 Amp
RATED POWER	0.175 Watt
RATED SPEED	19000 RPM $\pm$ 10%
	( in free air at rated voltage )
AIRFLOW	0.57 CFM
	( in free air at rated voltage )
STATIC AIR PRESSURE	3.05 mm water
	( in free air at rated voltage)
NOISE LEVEL	35 dB/A
MOTOR PROTECTION	BY IMPEDANCE
CONNECTION LEAD TYPE	WIRE, AWG# 32
LIFE EXPECTANCY	30,000 HOURS AT 25°C / 65%
NET WEIGHT	1.5 GRAMS
PACKING	960 PER CARTON

Unless otherwise stated, the relative humidity is 65%, and the temperature is 40°C for the standard testing.



6600 Park of Commerce Blvd.  
Boca Raton, Florida 33487  
www.jarothermal.com  
Ph: 561-241-6700  
Fx: 561-241-3328

JARO PART NUMBER: AD1505HX-0R4E-LF

## 1.0 SCOPE

- 1.1 This documentation defines the mechanical and electrical characteristics of DC brushless fans.
- 1.2 No guarantee is given to our product for use outside the limits of this specification.

## 2.0 MATERIAL

- 2.1 Frame : UL94V-0 Glass Filled Polyester (P.B.T.)
- 2.2 Fan Blade : UL94V-0 Glass Filled Polyester (P.B.T.)
- 2.3 Bearing System:  Sleeve, oil impregnated.  
 Two Ball Bearing – Extended Temp.  
 One ball one sleeve  
 Hypro Bearing  
 FDB Bearing
- 2.4 Lead Free  Yes

## 3.0 DIMENSIONS & CONSTRUCTION

All dimensions, Direction of rotation and air flow are specified per drawing attached.

## 4.0 CHARACTERISTICS & DEFINITION

- 4.1 All rated characteristics were specified as per data sheet enclosed.
- 4.2 Rated Current: Rated Current shall be measured after 3 minutes of continuous rotation at rated voltage.
- 4.3 Rated Speed: Rated Speed shall be measured after 3 minutes of continuous rotation at rated voltage.
- 4.4 Start Voltage: The voltage which is able to start the fan to operate by suddenly switching “ON”.
- 4.5 Input Power: Input Power shall be measured after 3 minutes of continuous rotation at rated voltage.
- 4.6 Locked Rotor Current: Locked current shall be measured within one minute of rotor locked, after 3 minutes of continuous rotation at rated voltage in clear air.
- 4.7 Air Flow & Static Pressure: The air flow data and static pressures should be determined in accordance with AMCA standard or DIN24163 specification in double chamber testing with intake – side measurement.
- 4.8 Noise Level: The measurement of noise level is carried out with reference to CNS8753 in an echoic chamber with the microphone positioned 1 meter from air intake. Testing fan shall be hung in clean air.

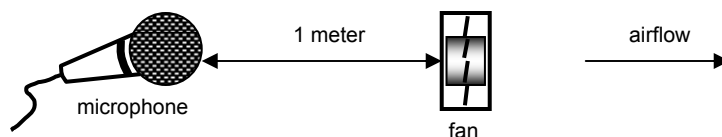



6600 Park of Commerce Blvd.  
Boca Raton, Florida 33487  
www.jarothermal.com  
Ph: 561-241-6700  
Fx: 561-241-3328

JARO PART NUMBER: AD1505HX-0R4E-LF

## 5.0 MECHANICAL INSPECTION

### 5.1 Rotation Direction

Clockwise with label side facing up. The same direction also indicated by arrow mark on the side of fan housing.

### 5.2 Protection

All fans have integrated protection against locked rotor condition so that there will be no damage to winding or any electronic component. Restarting is automatic as soon as any constraint to rotation has been released. Fan is placed at dean angle position, and the switch is changed from off to on. Restarting was automatic and proves fan is good.

### 5.3 Locked Rotor Protection

No Damage shall be found after 72 hours of continuous locked rotor . Restarting is automatic as soon as constraint to running has been released.

### 5.4 Avoid damage, please check the correct voltage and proper polarity before connecting to power.

### 5.5 Free Drop Shock

In minimum package condition. The fan should withstand drops on any three faces from a height of 30cm onto a wood board 10mm thick.

### 5.6 Please do not stick grease or oil into the fan housing or blade.

### 5.7 During testing of the fan, please make sure the finger guard is used for safety.

## 6.0 ELECTRICAL INSPECTION

6.1 Insulation Resistance. Not less than 10M ohm between housing and positive end of lead wire (red) at 500VDC.

6.2 Dielectric Strength. No damage should be found at 500VAC for 60 seconds. Measured with 5mA trip current between housing and positive lead wire.

### 6.3 Life Expectancy

The continuous duty life at given temperature after which 90% of the testing units shall still be running.

6.4 While the fan is running, do not intentionally lock the fan for a long time since the overheating of the motor produced by the long-time locking will damage the fan.

## 7.0 ENVIRONMENTAL

7.1 Improper use such as disassembling the fan, being covered with dust, or dipping the fan in water that results in defects is not covered in the warranty. Do not use the fan in a corrosive or liquid environment.

7.2 Operating Temp: -10°C to +60°C at 65% +/- 20% Relative humidity.

7.3 Storage Temp: 500 hrs at -40°C to +90°C (24 hour recovery at Room Temp)

### 7.4 Humidity

After 96 hours, 95% RH, 40±2°C per MIL-STD-202F. method 103B humidity test, the measured data on insulation resistance and dielectric strength shall meet specification.

7.5 Do not place or store fan in the environment with high/low humidity. Do not Store fan for over 6 months



6600 Park of Commerce Blvd.  
Boca Raton, Florida 33487  
www.jarothermal.com  
Ph: 561-241-6700  
Fx: 561-241-3328

JARO PART NUMBER: AD1505HX-0R4E-LF

8.0 REMARKS

8.1 Material and construction are subject to change without advance notice.  
The changes should be within specification.

8.2 All fans shall meet the quality inspection under sampling plan MIL-STD-105E  
as follows:

Critical	0.25%
Major	1.00%
Minor	2.50%

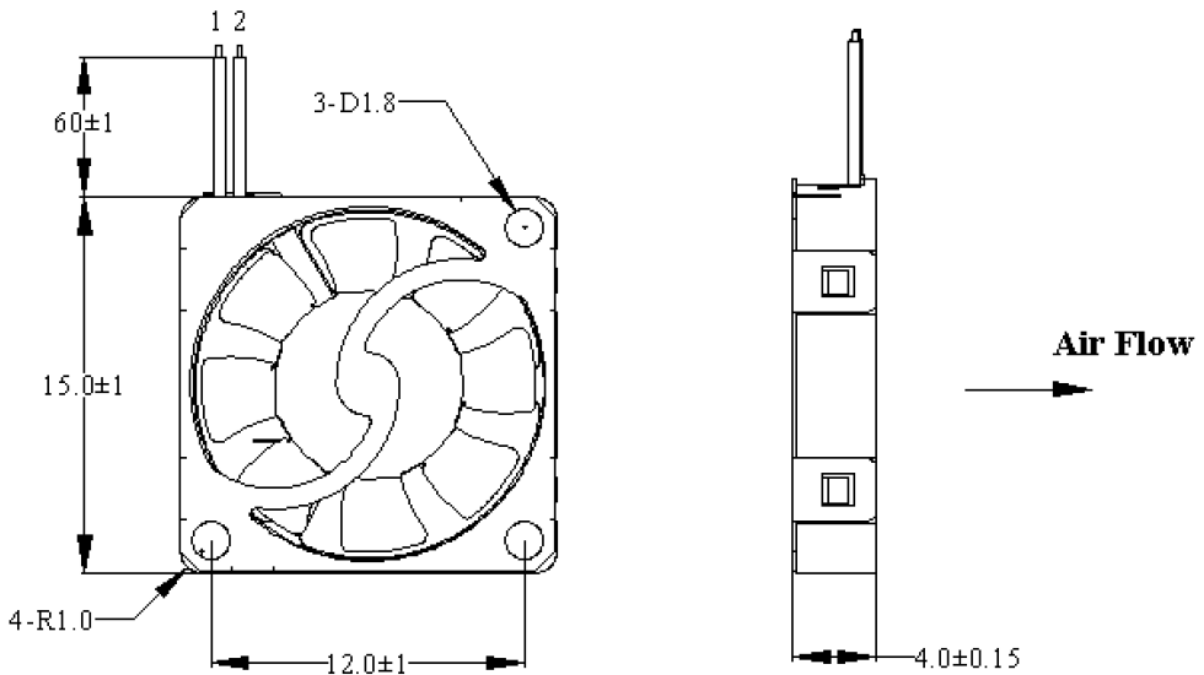

LEAD WIRES: UL1571 L = 50 ± 1 mm 32awg  
Red = positive ; Black = negative



6600 Park of Commerce Blvd.  
Boca Raton, Florida 33487  
www.jarothermal.com  
Ph: 561-241-6700  
Fx: 561-241-3328

JARO PART NUMBER: AD1505HX-0R4E-LF

### 10.0 NOTES

- 10.1 Please do not touch or push fan blade with fingers or other objects.
- 10.2 Do not carry the fan by its lead wires.
- 10.3 If the fan does not have polarity protection function, the connection of the colored wires should read red+red, and black+black. Improper wiring will cause immediate damage to fan
- 10.4 For fans without polarity protection, do not connect the wires in reverse

### 11 PQ Curve

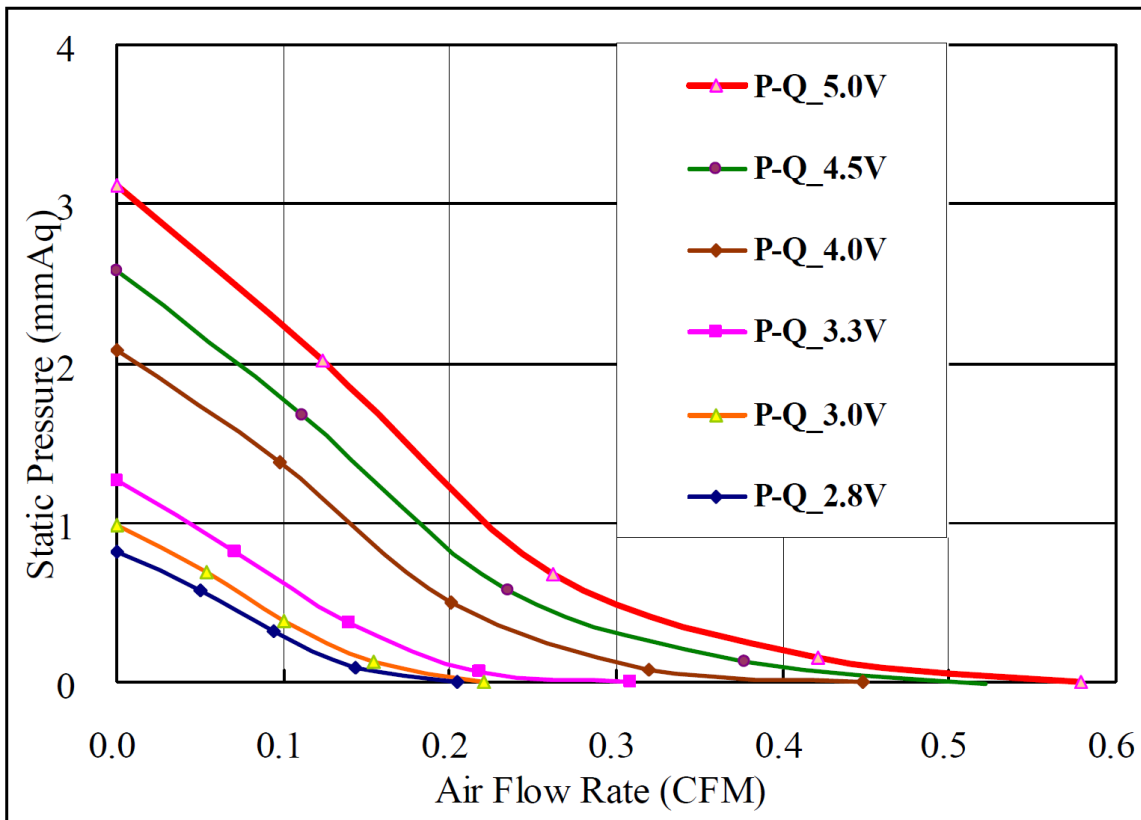

鴻進科技 壽命試驗報告

THE TEST REPORT OF MTTF

Date : 2010. 3. 5

Model NO.		AD1505HX-0R4E	Test Condition		Test Result	
Spec.	Speed	19,000 R.P.M.	Input Voltage	5.0 VDC	Failed Quantity	0
	Current	35 mA	Temperature	70°C	Conf. Level	90%
	Noise	35 dB	Humidity	No Control	Life Expectancy	20000
Sample Tested	20	Orientation	Vertical			
Test Hours per Sample	469 Hours	Running	In Free Air	MTBF		
<b>Test Condition</b>						
Specification temperature ( $T_n$ ) : 45°C Test Temperature ( $T_a$ ) : 70°C Activation Energy ( $E_a$ ) : 0.6 Acceleration Factor ( $A\eta$ ) : 4.921071			Acceleration factor : $A\eta = \exp \frac{E_a(\frac{1}{T_n} - \frac{1}{T_a})}{K}$ Total Test Time : $T = \frac{MTBF \times X^2}{2 \times A\eta}$			
<b>Failure Definition</b>			<b>Test Result</b>			
1. Not Functioning 2. Speed under 30% of original spec. 3. Current over 30% of original spec. 4. Noise over 5dB of original spec.			<u>Accu. F/Q</u>	<u>Accu. F/R</u>	<u>Finding</u>	
			0	0.00%	No Failure Found	
TEST PROCEDURES : – CHECK THE APPEARANCES OF SAMPLES BEFORE THE TEST. – INSTALL THE SAMPLES INTO THE CHAMBER AND SET UP TESTING CONDITION. – AFTER TESTING, TAKE OUT THE SAMPLES FROM THE CHAMBER. – INSPECT THE SAMPLES AND RECORD FOR ANY VISIBLE CHANGE AFTER THE TEST. SUMMARY : 1. NO VISIBLE DAMAGE WAS FOUND. 2. THE FUNCTION OF TESTED SAMPLES WAS RUNNING NORMALLY AFTER THE TEST.						
<b>Approved by</b>	C. C. Huang	<b>Checked by</b>	Vick Sun	<b>Issued by</b>	Jason Lee	