



6600 Park of Commerce Blvd.
 Boca Raton, Florida 33487
 www.jarothermal.com
 Ph: 561-241-6700
 Fx: 561-241-3328

SPECIFICATION FOR APPROVAL

DC Brushless Fan

JARO PART NUMBER: AP5212MX-E70(8)-LF
SAFETY APPROVAL: CE

SPECIFICATIONS	
ITEM	SPECIFICATION / CONDITION
DIMENSIONS	52 x 52 x 12mm
BEARING TYPE	HYPRO
RATED VOLTAGE	12.0 VDC
OPERATING VOLTAGE RANGE	10.8 VDC ~ 13.2 VDC
START-UP VOLTAGE	9.0 VDC
RATED CURRENT	0.07 Amp + 10% (MAX)
RATED POWER	0.84 watt
RATED SPEED	4300 RPM ± 10%
	(in free air at rated voltage)
AIRFLOW	9.3 CFM
	(in free air at rated voltage)
STATIC AIR PRESSURE	0.07 inch water
	(in free air at rated voltage)
NOISE LEVEL	20.8 dB
MOTOR PROTECTION	BY IMPEDANCE
CONNECTION LEAD TYPE	WIRE, AWG#28 X 130mm
LIFE EXPECTANCY	50000 HOURS AT 25°C
NET WEIGHT	25 GRAMS
PACKING	300 PER CARTON



6600 Park of Commerce Blvd.
Boca Raton, Florida 33487
www.jarothermal.com
Ph: 561-241-6700
Fx: 561-241-3328

JARO PART NUMBER: AP5212MX-E70(8)-LF

1.0 SCOPE

- 1.1 This documentation defines the mechanical and electrical characteristics of DC brushless fans.
- 1.2 No guarantee is given to our product for use outside the limits of this specification.

2.0 MATERIAL

- 2.1 Frame : Aluminum Alloy
- 2.2 Fan Blade : UL94V-0 Glass Filled Polyester (P.B.T.)
- 2.3 Bearing System: Sleeve, oil impregnated.
 Two Ball Bearing
 One ball one sleeve
 Hypro Bearing
 FDB Bearing

3.0 DIMENSIONS & CONSTRUCTION

All dimensions, Direction of rotation and airflow are specified per drawing attached.

4.0 CHARACTERISTICS & DEFINITION

- 4.1 All rated characteristics were specified as per data sheet enclosed.
- 4.2 Rated Current: Rated Current shall be measured after 3 minutes of continuous rotation at rated voltage.
- 4.3 Rated Speed: Rated Speed shall be measured after 3 minutes of continuous rotation at rated voltage.
- 4.4 Start Voltage: The voltage which is able to start the fan to operate by suddenly switching "ON".
- 4.5 Input Power: Input Power shall be measured after 3 minutes of continuous rotation at rated voltage.
- 4.6 Locked Rotor Current: Locked current shall be measured within one minute of rotor locked, after 3 minutes of continuous rotation at rated voltage in clear air.
- 4.7 Air Flow & Static Pressure: The air flow data and static pressures should be determined in accordance with AMCA standard or DIN24163 specification in double chamber testing with intake – side measurement.
- 4.8 Noise Level: The measurement of noise level is carried out with reference to CNS8753 in an echoic chamber with the microphone positioned 1 meter from air intake. Testing fan shall be hung in clean air.

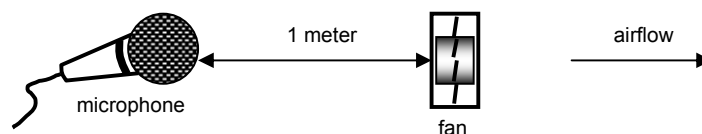



6600 Park of Commerce Blvd.
Boca Raton, Florida 33487
www.jarothermal.com
Ph: 561-241-6700
Fx: 561-241-3328

JARO PART NUMBER: AP5212MX-E70(8)-LF

5.0 MECHANICAL INSPECTION

5.1 Rotation Direction

Clockwise with label side facing up. The same direction also indicated by arrow mark on the side of fan housing.

5.2 Protection

All fans have integrated protection against locked rotor condition so that there will be no damage to winding or any electronic component. Restarting is automatic as soon as any constraint to rotation has been released. Fan is placed at dean angle position, and the switch is changed from off to on. Restarting was automatic and proves fan is good.

5.3 Locked Rotor Protection

No Damage shall be found after 72 hours of continuous locked rotor . Restarting is automatic as soon as constraint to running has been released.

5.4 Avoid damage, please check the correct voltage and proper polarity before connecting to power.

5.5 Free Drop Shock

In minimum package condition. The fan should withstand drops on any three faces from a height of 30cm onto a wood board 10mm thick.

5.6 Please do not stick grease or oil into the fan housing or blade.

5.7 During testing of the fan, please make sure the finger guard is used for safety.

6.0 ELECTRICAL INSPECTION

6.1 Insulation Resistance. Not less than 10M ohm between housing and positive end of lead wire (red) at 500VDC.

6.2 Dielectric Strength. No damage should be found at 1,500VAC for 60 seconds. Measured with 5mA trip current between housing and positive lead wire.

6.3 Life Expectancy

The continuous duty life at given temperature after which 90% of the testing units shall still be running.

6.4 While the fan is running, do not intentionally lock the fan for a long time since the overheating of the motor produced by the long-time locking will damage the fan.

7.0 ENVIRONMENTAL

7.1 Improper use such as disassembling the fan, being covered with dust, or dipping the fan in water that results in defects is not covered in the warranty. Do not use the fan in a corrosive or liquid environment.

7.2 Operating Temp: -10°C to +70°C at normal humidity.

7.3 Storage Temp: 500 hrs at -40°C to +70°C (24 hour recovery at Room Temp)

7.4 Humidity

After 96 hours, 95% RH, 40±2°C per MIL-STD-202F. method 103B humidity test, the measured data on insulation resistance and dielectric strength shall meet specification.



6600 Park of Commerce Blvd.
Boca Raton, Florida 33487
www.jarothermal.com
Ph: 561-241-6700
Fx: 561-241-3328

JARO PART NUMBER: AP5212MX-E70(8)-LF

8.0 REMARKS

8.1 Material and construction are subject to change without advance notice.
The changes should be within specification.

8.2 All fans shall meet the quality inspection under sampling plan MIL-STD-105E
as follows:

Critical	0.25%
Major	1.00%
Minor	2.50%

9.0 OUTLINE SYLING AND DIMENSIONS (Shown in millimeters)

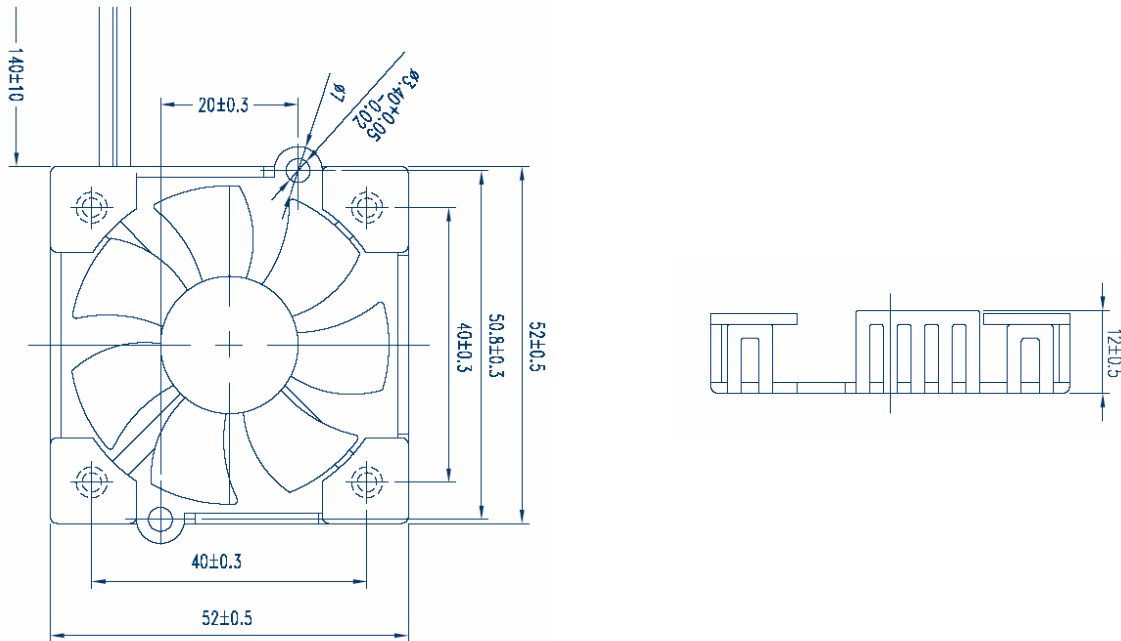

LEAD WIRES: UL 1571, AWG28, L = 130 ± 10 mm
Red = positive ; Black = negative